

# BVM SLX SERIES ELEVATOR

SLX ELEVATORS ARE CONVENTIONAL SIDE DOOR ELEVATORS USED FOR HANDLING CASING RANGING IN SIZE FROM 4 1/2" TO 36".

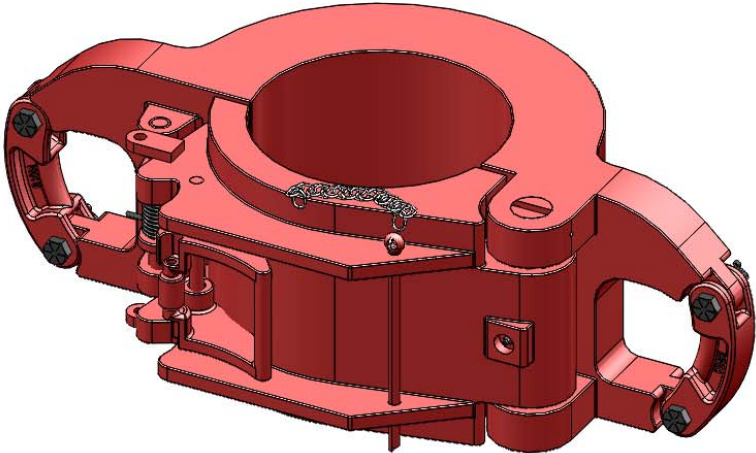
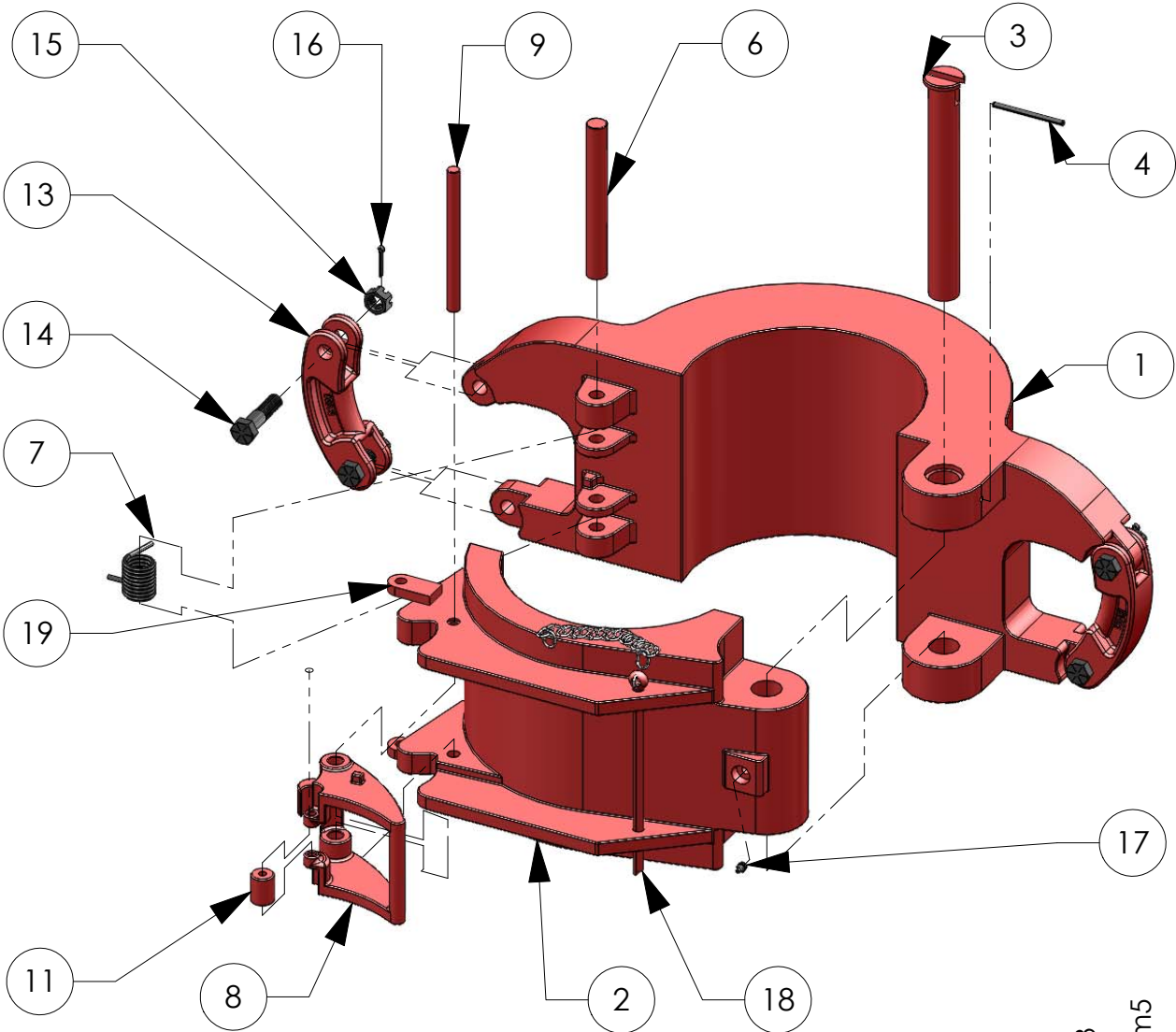

**BVM CORPORATION**  
430 S. NAVAJO STREET, DENVER CO 80223  
PHONE: 303-975-1402; FAX: 303-975-0981  
www.bvmcorp.com; sales@bvmcorp.com5

# BVM SLX SERIES ELEVATOR

REF NO.	DESCRIPTION	NO. REQ	SLX 100	SLX 150	SLX 150	SLX 150	SLX 150	SLX 150	SLX 150
			4 1/2" - 5 1/2"	4 1/2" - 8 5/8"	9 5/8"-10 3/4"	11 3/4"-13 3/8"	16"-20"	24" - 30"	36"
			33854-***	31239-***	33950-***	33982-***	33632-***	33175-***	33180-***
1	BODY	1	33854LC	31239LC	33950LC	33982LC	33632LC	33175LC	33180LC
2	DOOR	1	33854RC	31239RC	33950RC	33982RC	33632RC	33175RC	33180RC
3	HINGE PIN	1	34613	34611	33953	33985	33646-3*	34179-3*	34179-2*
4	HINGE PIN RETAINER	1	-	-	-	-	40040-32-0	40040-30-0	40040-30-0
5	LATCH	1	33813	31331	31331	31331	33634	33634	33634
6	LATCH PIN	1	29980-4	32424-3	32424-3	32424-3	33645-1	33645-1	33645-2
7	LATCH SPRING	1	33818	31383	31383	31383	33657	33657	33657
8	LATCH LOCK	1	33812	31332	31332	31332	33635	33635	33635
9	LATCH LOCK PIN	1	29980-3	29980-4	29980-5	29980-5	50713	50713-1	32424-2
10	LATCH LOCK SPRING	1	33816	31404	31404	31404	33658	33658	33658
11	ROLLER	1	31407	31407	31407	31407	31407	31407	31407
12	ROLLER PIN	1	31584	31584	31584	31584	31584	31584	31584
13	LINK BLOCK	2	32430	9519	9519	9519	9519	9519	9519
14	LINK BLOCK BOLT	4	939051-65	8145	8145	8145	8145	8145	8145
15	LINK BLOCK NUT	4	6810C-00-5	6812C-00-5	6812C-00-5	6812C-00-5	6812C-00-5	6812C-00-5	6812C-00-5
16	COTTER PIN	4	30AB0-14-0	30AB0-14-0	30AB0-14-0	30AB0-14-0	30AB0-14-0	30AB0-14-0	30AB0-14-0
17	GREASE FITTING	1	940308-1	940308-1	940308-1	940308-1	940308-1	940308-1	940308-1
18	PIN & CHAIN ASSEMBLY	1	10571-1	10571-2	10571-3	10571-2	10571-4	10571-4	10571-4
19	SAFETY PIN SUPPORT HANDLES	2	10428	10428	10428	10428	10428	10428	10428
		2	-	-	-	-	1360-14	1360-14	1360-14

REF NO.	DESCRIPTION	NO. REQ	SLX 250	SLX 250	SLX 250	SLX 250	SLX 250	SLX 250
			6 5/8" - 8 5/8"	9 5/8"-10 3/4"	11 3/4" - 13 3/8"	16" - 24"	24" - 30"	36"
			43239-***	43950-***	43982-***	43632-***	43175-***	43180-***
1	BODY	1	43239LC	43950LC	43982LC	43632LC	43175RC	43180LC
2	DOOR	1	43239RC	43950RC	43982RC	43632RC	43175LC	43180RC
3	HINGE INP	1	33646-2	33646-2	33646-1	34179	34179-3*	34179-2*
4	HINGE PIN RETAINER	1	-	-	-	-	40040-30-0	40040-30-0
5	LATCH	1	31331	31331	33634	33634	33634	33634
6	LATCH PIN	1	33645	32424-3	33645-2	33645-1	33645-1	33645-2
7	LATCH SPRING	1	31383	33657	33657	33657	33657	33657
8	LATCH LOCK	1	31332	31332	33635	33635	33635	33635
9	LATCH LOCK PIN	1	32424-3	29980-5	32424-2	32424-2	50713-1	32424-2
10	LATCH LOCK SPRING	1	31404	33658	33658	33658	33658	33658
11	ROLLER	1	31407	31407	31407	31407	31407	31407
12	ROLLER PIN	1	31584	31584	31584	31584	31584	31584
13	LINK BLOCK	2	9519	9519	9519	9519	9519	9519
14	LINK BLOCK BOLT	4	8145	8145	8145	8145	8145	8145
15	LINK BLOCK NUT	4	6812C-00-5	6812C-00-5	6812C-00-5	6812C-00-5	6812C-00-5	6812C-00-5
16	COTTER PIN	4	30AB0-14-0	30AB0-14-0	30AB0-14-0	30AB0-14-0	30AB0-14-0	30AB0-14-0
17	GREASE FITTING	1	940308-1	940308-1	940308-1	940308-1	940308-1	940308-1
18	PIN & CHAIN ASSEMBLY	1	10571-3	10571-4	10571-4	10571-4	10571-4	10571-4
19	SAFETY PIN SUPPORT HANDLES	2	10428	10428	10428	10428	10428	10428
		2	-	-	-	1360-14	1360-14	1360-14

\* = For Elevator P/N 33632 of S/N 28619 and Lower, Use P/N 33646  
 For Elevator P/N 33175 of S/N 27428 and Lower, Use P/N 34179  
 For Elevator P/N 43175 of S/N 31042 and Lower, Use P/N 34179  
 For Elevator P/N 33180 of S/N 29235 and Lower, Use P/N 34179-1  
 For Elevator P/N 43180 of S/N 30476 and Lower, Use P/N 34179-1  
 Otherwise, use P/N indicated in the Table

\*\*\* = See Bore Code Charts